

# 4-CABLE FLOOR TO CEILING SIGN/SHELVING/ROD SYSTEM

BILL OF MATERIALS		
ITEM #	GRIPLOCK P/N	QTY.
1	DG-CC-SAT	4
2	DAS-25-71-xxx*	4
3	DG-GSOM-SAT	2
4	DG-25-SOM-SAT	2
5	DG-25-SMU-SAT	6
6	DG-TNS-SAT	4

\*xxx is length of cable in inches.  
Stock lengths are 60", 120", 180" & 240"

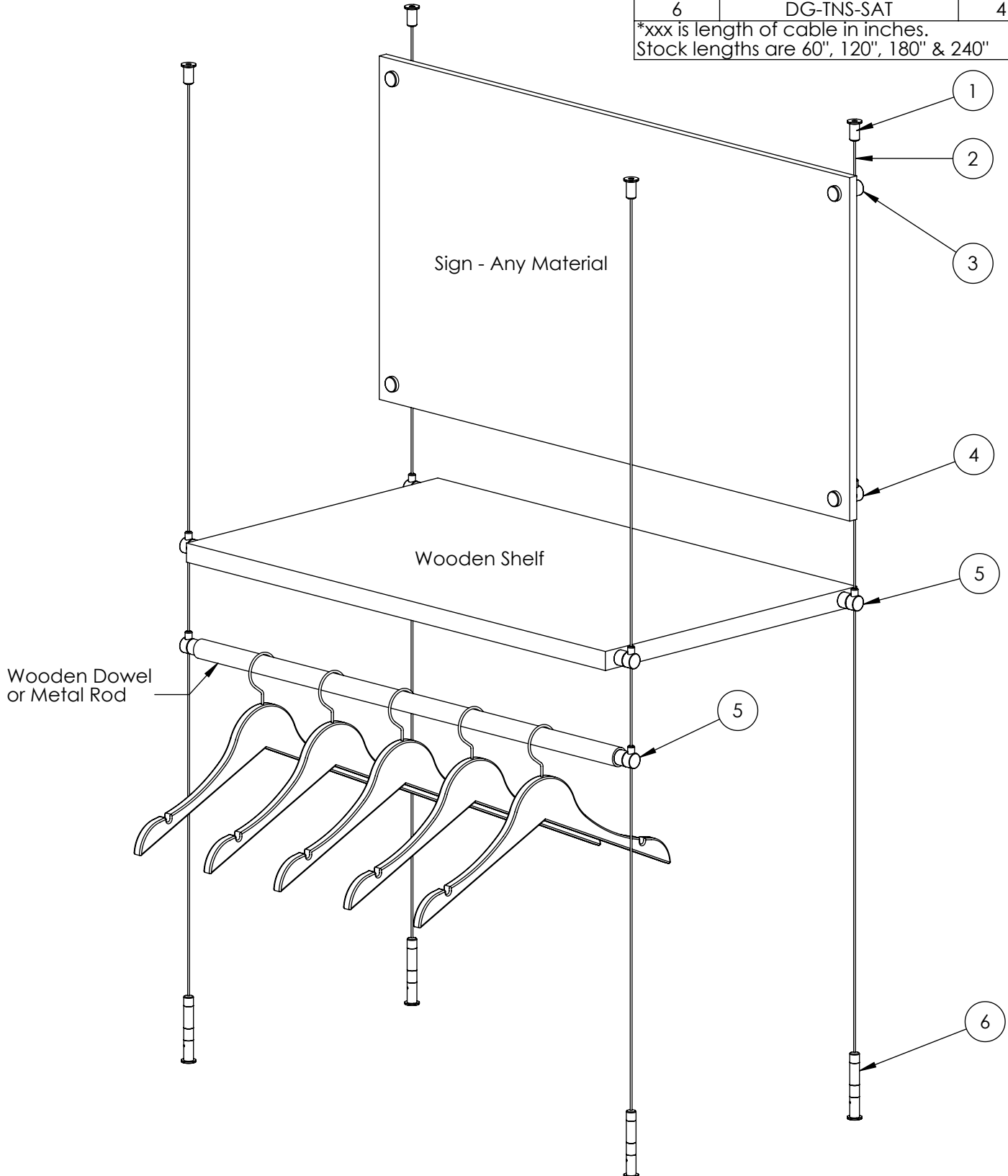

DATE: 08/29/08

SCALE: 1:7

FILE: Floor to Ceiling Sign-Shelf-Rod Side Mount System

**PROPRIETARY AND CONFIDENTIAL**

This drawing and these specifications are the exclusive property of GRIPLOCK SYSTEMS LLC and shall not be divulged, reproduced, copied, or used as the basis for the manufacture or sale of apparatus without the express written authorization of GRIPLOCK SYSTEMS LLC.



**GRIPLOCK SYSTEMS**

410 Palm Ave. Loft A18, Carpinteria, CA 93013  
Phone (805) 566-0064 Fax (805) 566-0065  
www.griplocksystems.com

# 4-CABLE SHELVING SYSTEM WITH SIDE CLAMPS

BILL OF MATERIALS		
ITEM #	GRIPLOCK P/N	QTY.
1	DG-CC-APLT-SAT	4
2	DAS-25-71-xxx*	4
3	DG-25-SCU-SAT	16
4	DG-TNS-APLT-SAT	4

\*xxx is length of cable in inches.  
Stock lengths are 60", 120", 180" & 240"

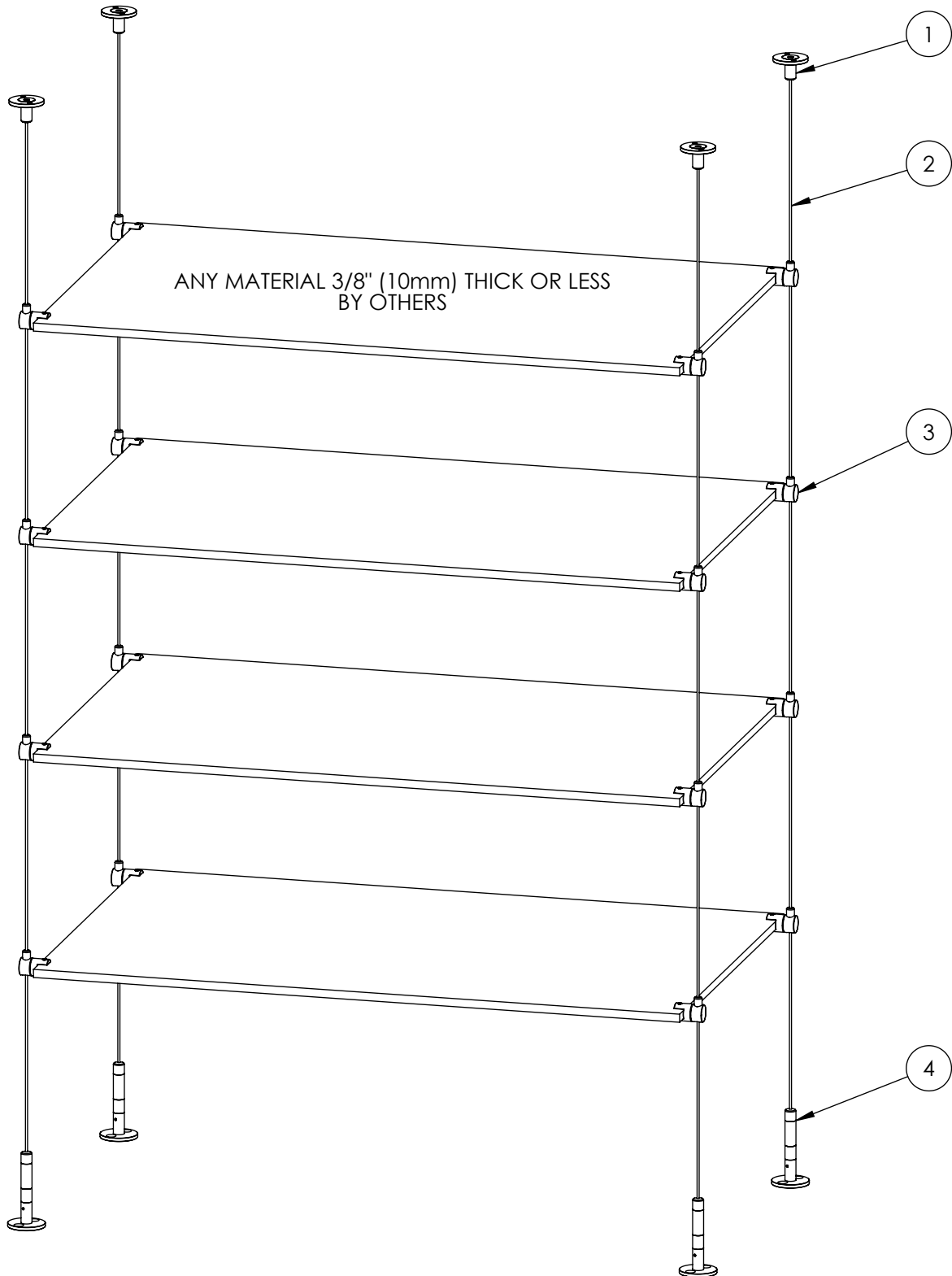

DATE: 07/15/08

SCALE: 1:7

FILE: Floor to Ceiling Shelving w  
DG-25-SCU-SAT & APLT

**PROPRIETARY AND CONFIDENTIAL**

This drawing and these specifications are the exclusive property of GRIPLOCK SYSTEMS INC. and shall not be divulged, reproduced, copied, or used as the basis for the manufacture or sale of apparatus without the express written authorization of GRIPLOCK SYSTEMS INC.



**GRIPLOCK SYSTEMS**

410 Palm Ave. Loft A18, Carpinteria, CA 93013  
Phone (805) 566-0064 Fax (805) 566-0065  
www.griplocksystems.com

# BANNER ROD/HANGING RACK CEILING HUNG SYSTEM

BILL OF MATERIALS		
ITEM #	GRIPLOCK P/N	QTY.
1	DG-CC-CPLT-SAT	2
2	DAS-20-87-xxx*	2
3	DG-25-SMU-SAT	2
4	DG-CT-SAT	2

\*xxx is length of cable in inches.  
Stock lengths are 60", 120", 180" & 240"

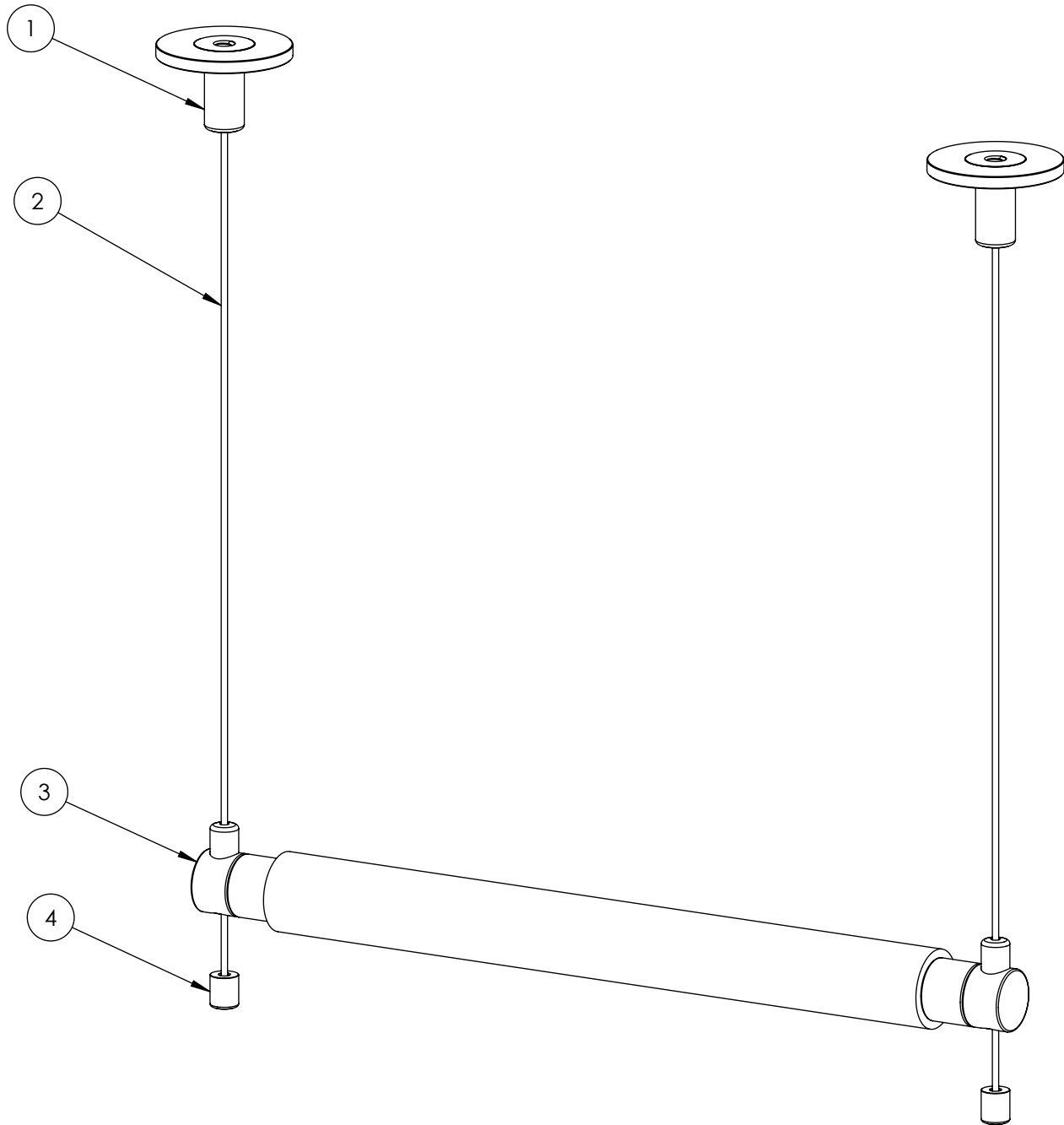

DATE: 08/27/08

SCALE: 1:2

FILE: Bannerrod - hanging rack ceiling hung system w ceiling cover plate

**PROPRIETARY AND CONFIDENTIAL**

This drawing and these specifications are the exclusive property of GRIPLOCK SYSTEMS LLC and shall not be divulged, reproduced, copied, or used as the basis for the manufacture or sale of apparatus without the express written authorization of GRIPLOCK SYSTEMS LLC.



**GRIPLOCK SYSTEMS**

410 Palm Ave. Loft A18, Carpinteria, CA 93013  
Phone (805) 566-0064 Fax (805) 566-0065  
www.griplocksystems.com